

Powder Induction and Dispersion System

Advanced Mixing Technologies

Admix introduces the latest technology in high performance ergonomic feeding and dispersion of dry ingredients into marinade and brine preparation tanks.

The Fastfeed is an integrated, skid mounted inline powder induction and dispersion system using a specially designed powder suction pump and proven high shear mixing technology for rapid incorporation and wetting out of difficult powders.

Process Features and Benefits

- ✓ Optimum powder feed rates up to 72,5 kg/min
- ✓ Insure full functionality of ingredients
- ✓ Reduce minimum batch size
- ✓ Easily handle higher viscosity marinades
- ✓ Reduce foaming and air entrainment
- ✓ Optional wand available for easy liquid additions
- ✓ Safely dump powders from floor level
- ✓ Eliminate wasted brine and ingredients
- ✓ Reduce mixer maintenance
- ✓ Increase yields especially on injected products
- ✓ Eliminate "bath tub ring" in mix tanks
- ✓ Shorter mix times
- ✓ Eliminate in-tank high shear mixers
- ✓ Supply multiple tanks with one unit



The Fastfeed Powder Induction & Dispersion System

The Fastfeed is unlike any other powder induction system, which typically relies on an eductor, venturi, or negative pressure generated by a high-speed mix head. The Fastfeed uses a high performance powder suction pump that vacuum conveys from 2 to over 72,5 kg/min of any powder, including hard to handle soy proteins, starches, phosphates, spices and powdered broth.

The design of the Fastfeed allows for continuous powder suction even as the viscosity and solids level increase... insuring that the system will never plug or foul.

For the meat and poultry processor, we have developed a unit to provide accurate, fixed powder feed rates and require no adjustments by the operator. Its design is easy-to-use and insures that the proper concentration of dry materials are added quickly and effectively. Complete 100% dispersion of powders is guaranteed as the powder slurry mixture is passed through the high speed DynaShear inline high shear mixer, where most formulas are finished in less than 5-minutes of re-circulation [after all ingredients are added]. This insures full functionality of ingredients and consistently high yields.

The table below illustrates typical powder feed rates of our Fastfeed.

Performance Table for Fastfeed FF-425R

Examples of Typical Ingredient Type	Maximum Powder Feed Rate (kg/min)
Phosphates	63,5 - 72,5
Salt	36 - 45,5
Soy protein	18 - 27
Modified starch	13,5 - 27
Carrageenan	13,5 - 18
Broth	27 - 36
Spice	18 - 50

Model	Pump	Mixer	Hopper	Skid Fittings
FF-425R	5,5 kW @ 1.800 rpm	4 kW @ 3.600 rpm	100 liters	50,8 mm TriClamp® inlet 50,8 mm TriClamp® outlet

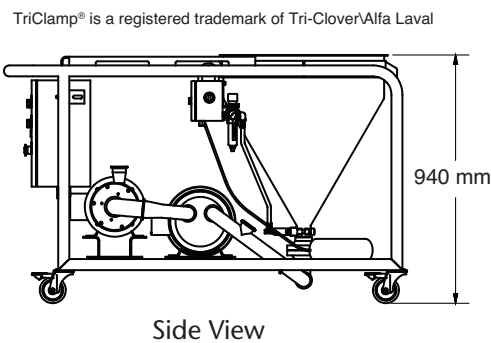
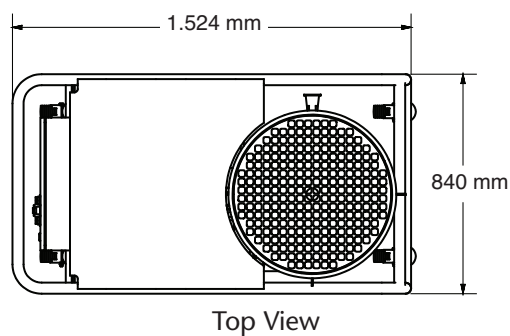

For more information:

EMPLOYEE OWNED...
CUSTOMER FOCUSED

Advanced Powder Induction and Dispersion

How and Why it Works

The Fastfeed combines the suction capability of a "vacuum pump", with the wetting out and shearing capabilities of a high speed, inline high shear mixer, all within an easy-to-use ergonomic package. Powder is fed into the hopper from bags as shown on the cover.

Powder bridging or rat holing is eliminated by the combination of the suction pump creating a constant vacuum within the flow stream, aided by a mechanical vibrator for the more challenging ingredients.

Once powder is sucked in through the pump, instantaneous shearing and fluidization of the powder begins, and this slurry is quickly pumped through our DynaShear inline high shear mixer providing droplet and soft particle size reduction down to 4 to 5 microns upon exiting the unit.

Powder feed rate is controlled with factory settings, insuring controlled, but rapid, dispersion and at the proper concentrations to prevent product slugs or premature hydration.

While many ingredients can be 100% dispersed with one pass, the Fastfeed pump and skid should be configured on a recirculation loop for multiple passes through the DynaShear. A single Fastfeed skid can also be used to feed multiple tanks.

Mechanical Features

- All contact surfaces are 316L with welds blended & polished
- NEMA 4X control panel
- Optional wand for liquid additions
- Minimized piping and connections for quick disassembly & reassembly

See it in action at
www.admix.com/fastfeed.htm